



SJ63 AJ ARTICULATING BOOM

Combining a working height of 21.38 m, a horizontal reach of 12.19 m, and an up and over clearance of 8.38 m, Skyjack's SJ63 AJ is designed for versatility. Superior positive traction and terrainability is provided by the axle based 4WD used in many of Skyjack's product designs, which accounts for a proven low maintenance, rugged and reliable drive train. 360 degree turret rotation and zero tail swing allow for flexible operation in tight locations.

The SJ63 AJ has a unique open centre knuckle riser design for improved visibility and compact dimensions, it also features "straight boom functionality" allowing the boom to reach the ground with the riser fully elevated, increasing productivity and give below ground reach capabilities. Dual lift cylinders provide comfort and stability, while maintaining true vertical rise, which prevents any forward or backwards drift. Other key features include; direction sensing drive and steer controls, analog based controls and Skyjack's standard colour coded and numbered wiring system.



SKYJACK

ARTICULATING BOOM LIFTS

SPECIFICATIONS

SJ63AJ

AS/NZS 1418.10:2011

Work Height	21.38 m
Platform Height	19.38 m
Horizontal Reach	12.19 m
Up and Over Height	8.38 m
Platform Size	0.91 x 2.44 m
Stowed Width	2.44 m
Tailswing	Zero
Stowed Height	2.54 m
Stowed Length	9.14 m
Wheelbase	2.44 m
Ground Clearance	0.33 m
Rotation	360°
Platform Rotation	175°
Jib Length	1.68 m
Jib Range +/-	+65° / -60°
Weight	10045 kg
Gradeability	45%
Turning Radius (Inside)	2.21 m
Turning Radius (Outside)	5.31 m
Axle Oscillation	0.20 m
Drive Speed (High speed)	7.3 km/h
Capacity	227 kg
Local Floor Load (With Rated Load)	793 kPa
Overall Floor Load (With Rated Load)	12 kPa
Maximum # of Persons	2
Tyre Type	Grip lug foam-filled
Diesel Engine	65 HP
Fuel Tank Capacity	115 L
Hydraulic Reservoir	115 L

STANDARD FEATURES

- Axle based 4WD system
- Operator controlled locking rear differential and limited slip front differential
- Oscillating axle
- Drivable at full height
- Straight boom functionality
- 360° continuous turret rotation
- 45% Gradeability
- Swing out engine tray
- Swing up cowlings
- Modular platform railing system
- Tri-entry sliding mid-rail
- Wiring for AC outlet to platform
- Direction sensing drive and steer controls
- Proportional controls
- Relay based control system
- Colour coded and numbered wiring
- Hourmeter
- Operator horn
- All motion alarm
- Load sensing system
- Tie down/lifting lugs
- Wet disc SAHR brakes (front and rear axle)
- Grip lug foam-filled tyres

OPTIONS†

- 0.91 x 1.83 m Platform
- Airline to platform
- 3.5 kW generator (includes hydraulic oil cooler)
- Cold weather start kit (includes cold start engine oil, battery blanket, and hydraulic tank heater)
- Diesel scrubber
- Hydraulic oil cooler
- Flashing light
- 1/2" airline to platform
- Hostile environment package (includes cylinder bellows, boom wipers, covers for the fly boom cutouts, and control box cover.)
- Auxiliary top rail
- Control box cover
- Pipe rack
- Rear Gate

Tyre Options ‡

- Non marking foam filled tyres

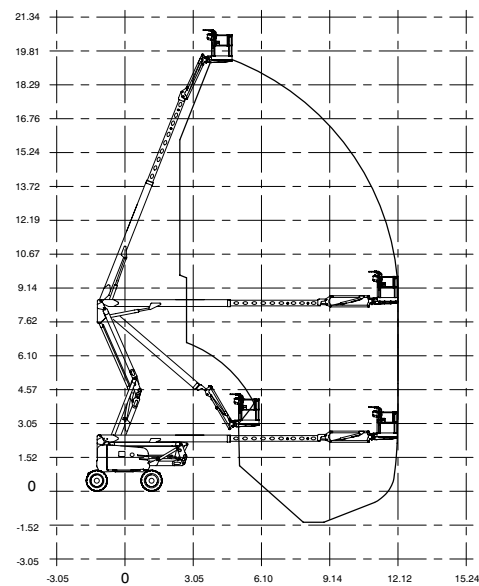

SJ63 AJ

‡ Standard lead times may be increased when optional equipment is added, consult factory

** Capacities, and machine weights may differ when options are added

Skyjack Australia Pty Ltd

4 Coates Place
Wetherill Park
New South Wales, 2164
Tel: +61 (0) 2878 63200
Fax: +61 (0) 2878 63222
Email: jcranmer@skyjack.com

www.skyjack.com



SKYJACK™

This brochure is for illustrative purpose only and based on the latest information at the time of printing. Skyjack Inc. reserves the right to make changes at any time, without notice, to specifications, standard and optional equipment. Consult the Operating Maintenance and Parts Manuals for proper procedures. AS marked platforms are in conformance to Standard AS/NZS 1418.10:2011.

AU/NZ/01/2013